

T348 MiniSCSI™ Plus Parallel-to-SCSI Adapter

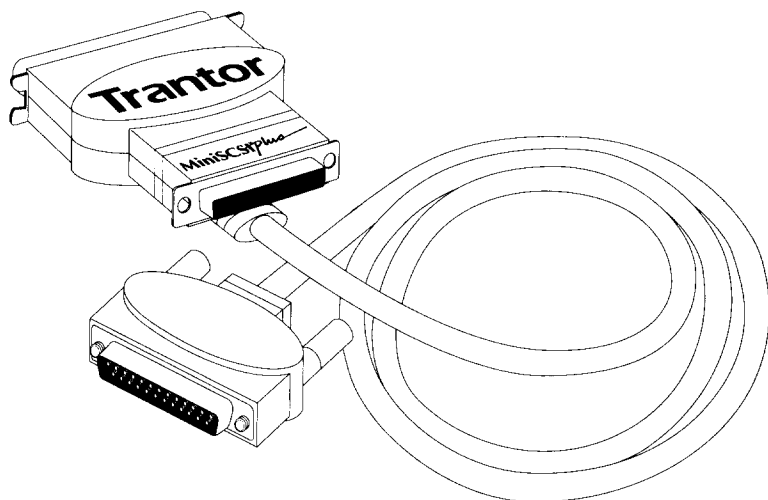

Hardware Installation Guide

NOTE

If you're like many users, you'll want to get started using your new equipment as soon as possible. But, before you attempt to install and use your **MiniSCSI Plus** adapter, please read this guide. It will save you time in the long run, and make you aware of many options you might otherwise miss. Remember, you can always change your system configuration at a later time.

For technical support of this product, please see your dealer first for assistance, as he/she is most likely to understand your specific needs and equipment setup. To be eligible for any Trantor factory technical support which may be necessary, your Product Registration Card **must** be on file with us.

Please fill out and mail in your Product Registration Card within 10 days of purchase!

1.0 Introduction

This guide describes installation and operation of the Trantor™ T348 **MiniSCSI Plus** adapter (hereafter referred to as **MiniSCSI Plus** adapter) for IBM®-compatible computer systems.

Your **MiniSCSI Plus** adapter has been designed to provide simple, flexible control of most SCSI hard disks, removable-cartridge disks, Floptical® drives, magneto-optical drives, SCSI-interfaced Bernoulli® and SyQuest® drives, SCSI floppy and tape drives, CD-ROMs (including Kodak® Photo CD) and HP® ScanJet® II scanners. Some of the important features include:

- High-speed operation—the **MiniSCSI Plus** adapter is fully compatible with bidirectional parallel ports, offering excellent performance, while remaining compatible with unidirectional ports found on many older computer systems.
- Simple installation—with the integral 3-foot lightweight cable, just plug it into your parallel printer port and connect to your SCSI device(s) and printer.
- Both SCSI and parallel printer interfaces may be operated simultaneously, with no performance degradation.
- Standard SCSI interface connector, permitting the use of almost any SCSI-compatible device.
- Small size and light weight for easy portability.
- No battery or external power supply needed—the **MiniSCSI Plus** adapter is powered by the SCSI device(s) connected to it.
- Supports virtually any PC/XT/AT, 80386, 80486, Micro Channel® or notebook computer with a parallel printer port.

1.1 Hardware Requirements

The **MiniSCSI Plus** adapter is designed to be as universally usable as possible, but there are five primary hardware compatibility requirements:

- The parallel port must be "standard," i.e. have a fully IBM-compatible hardware design, including all ground lines. For highest performance, the computer's parallel port must be capable of bidirectional operation.
- The SCSI device(s) connected to the **MiniSCSI Plus** adapter must have the standard ANSI SCSI-specification TERMPower implemented, as the **MiniSCSI Plus** adapter draws its power from this line. See your dealer for details.
- The SCSI device chain must be properly terminated as per ANSI SCSI specifications.
- IBM or compatible AT®, PS/2®, or similar computer.
- A 100% IBM-compatible BIOS. Operation with some incompatible BIOSs may be possible but is not guaranteed.

1.2 Checklist

You should have received the following items in your **MiniSCSI Plus** package:

- MiniSCSI Plus** SCSI host adapter
- 3.5-inch, 1.44-MB high-density distribution diskettes
- Hardware Installation Guide* (this document)
- Software User Guide*
- Product Registration card
- Microsoft® MSCDEX Registration card

If anything is missing, please contact your dealer immediately.

2.0 Hardware Installation

Hardware installation involves plugging the **MiniSCSI Plus** adapter into a parallel printer port and connecting it to the applicable SCSI device(s). Please see *Section 3.0* for troubleshooting assistance with possible problems which may develop.

WARNING

Since your **MiniSCSI Plus** hardware is powered via the SCSI device(s) connected to it, please **TURN OFF** the computer, printer and SCSI devices when connecting or disconnecting the **MiniSCSI Plus** hardware; this will protect against damage to any components.

In addition, if you disconnect your SCSI device(s) from the **MiniSCSI Plus** adapter while in use, the **MiniSCSI Plus** adapter will lose power and not recognize the SCSI device(s) when reconnected. Reboot your computer in this case.

To install the **MiniSCSI Plus** adapter, follow these instructions:

1. Connect your **MiniSCSI Plus** parallel connector (see *Figure 1*) to a parallel printer port on your computer; you may use either LPT1, LPT2 or LPT3—the **MiniSCSI Plus** drivers will automatically detect which port is in use.

Note: if your parallel printer port has a copy-protection device (commonly known as a "dongle") or other non-printer product connected to it, you

should remove the device from your printer port and connect it to the printer passthrough connector on the **MiniSCSI Plus** adapter, rather than leaving it connected between your computer and the adapter. If this arrangement causes any problems, either the "dongle" or the **MiniSCSI Plus** adapter will have to be relocated to a different parallel port.

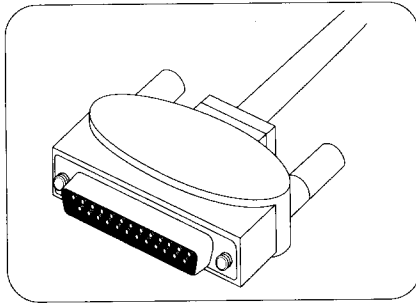

Figure 1 Parallel Connector

2. Connect the first SCSI device to the SCSI connector on the **MiniSCSI Plus** adapter (see *Figure 2*). Other SCSI devices (up to 7 total) may be daisy-chained to the first SCSI device; see your dealer for details if you are not familiar with multiple-device connections.

The SCSI device(s) connected to the **MiniSCSI Plus** adapter provides power to the **MiniSCSI Plus** adapter, and thus

must be equipped with the standard TERMPower output (which is part of the SCSI connector interface specification). See your SCSI device manual or dealer to confirm that this is the case. Your **MiniSCSI Plus** adapter will not operate without TERMPower.

The last (or only) SCSI device connected to the **MiniSCSI Plus** adapter should be properly "terminated," per manufacturer's specifications. See your dealer for termination assistance if necessary.

If you connect more than one SCSI device to your **MiniSCSI Plus** adapter simultaneously, make sure that each device's SCSI "address" (device number between 0 and 7) is different. Different addresses are essential to prevent conflicts when the **MiniSCSI Plus** adapter communicates with the devices.

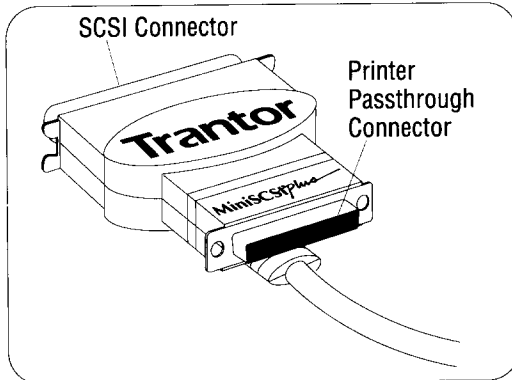

Figure 2 SCSI and Printer Passthrough

3. If you wish to simultaneously use a parallel printer with your **MiniSCSI Plus** adapter, connect it to the **MiniSCSI Plus** printer passthrough connector (see *Figure 2*) with a standard parallel printer cable. No special configuration or switching is needed to continue using your printer.

Note that the printer port on the **MiniSCSI Plus** adapter is operable only while it is powered up; if you disconnect or turn off the SCSI device connected to the adapter, the printer passthrough port on the adapter will no longer function.

At this point, load the software as explained in the *Software Users Guide*.

3.0 Common Error Messages and Remedies

Note: even though you may create a bootable partition with your **MiniSCSI Plus** adapter using TFORMAT, you will not be able to boot your computer with this partition through your **MiniSCSI Plus** adapter. Your computer does not expect to boot from a device connected to the parallel port. Therefore, your **MiniSCSI Plus** adapter device drivers must be loaded during the boot process from another disk. However, you can use a bootable partition created by your **MiniSCSI Plus** adapter when the SCSI drive is connected to any of Trantor's other SCSI Host Adapters which plug into a conventional expansion slot. If you do not plan to use the drive with any other host adapter, a bootable partition is not necessary.

"No SCSI Host Adapter Detected" Message Appears During Bootup

- *Improper or missing SCSI device termination power.*

Your **MiniSCSI Plus** adapter requires SCSI termination power in order to operate. Check to be sure that there is proper termination power available from your SCSI device. You can do this with a voltmeter by measuring the voltage available between pin 38 and ground on the SCSI device's connector (see *Section 5.0* for pinout details). Check this voltage with power to the SCSI device(s) on; it should measure approximately +5 volts. Very low or no voltage at pin 25 indicates a problem with termination power; this condition will disable the **MiniSCSI Plus** adapter.

Try this quick test, plug a printer into the printer pass-through port. If you have correct TERMPower, the printer will print.

Notes

- If your computer is part of a network installation, your printer port may be "redirected" to a network printer. For instance, Novell[®] NetWare[®] software uses the CAPTURE command for this purpose. If this is the case, the software will not detect the hardware at bootup. The simplest solution is to change your computer's parallel port hardware to LPT2 or LPT3, or change your network redirection to a different port.
- Some older-model 8086-based Sharp[®] laptops have a problem with their parallel port and will not work properly with the **MiniSCSI Plus** adapter, or with other programs that use high speed parallel port data transfer such as LapLink[®] or DeskLink[®] from Traveling Software. Sharp offers a free hardware upgrade for customers experiencing this problem; contact your Sharp dealer for details.

4.0 Maximizing Performance

After your **MiniSCSI Plus** adapter has been installed and tested, and you are sure it's working properly, it may be possible to improve its performance even further. We've found that, in many system configurations, implementing a special data-transfer mode can result in a 15-20% speed improvement!

Prior to trying out the techniques described below, make sure that your SCSI hardware and software is properly installed, configured and running without problems. Attempts to improve performance may not work on your particular installation. Knowing that the basic installation is working will aid in determining whether performance enhancements will work as well. In addition, there is a

small chance that data corruption may occur with incompatible configurations, so make sure that important data on your SCSI device(s) is backed up prior to trying this technique.

4.1 What is this Technique?

By default, your software is configured to operate in "full handshaking" mode. This means that data transfer between your computer and the SCSI device(s) via the **MiniSCSI Plus** adapter is performed in a manner that automatically confirms its accuracy. If there are timing, electrical noise, or other problems that disturb accurate data flow, the error is automatically detected and corrected without any user intervention. This mode assures that movement of information back and forth is error-free. Full handshaking requires more interaction by the software, however, which results in somewhat lower performance than if handshaking were disabled.

The good news is that you have the option to disable full handshaking and operate your SCSI installation in so-called "blind" mode. We've discovered that many **MiniSCSI Plus** adapter configurations will operate perfectly well (and faster) in blind mode. Full handshaking mode is safe for all installations, so that's the default configuration, but the /M software switch allows you to turn it off to test whether you can use the faster blind mode. The /M switch has four possible settings and is set in your CONFIG.SYS file on the ASPI Manager line:

- /M0 Standard full handshaking mode (default)
- 1 Blind mode enabled for higher performance
- 2 Full handshaking, force unidirectional (see *Section 4.3*)
- 3 Blind mode, force unidirectional (see *Section 4.3*)

So /M1 enables blind mode, and /M0 (or no /M entry) is standard full handshaking. The change is made to the line beginning with **DEVICE=MA348.SYS** in your CONFIG.SYS file, using any standard text editor, such as DOS 5's EDIT command. So, for example, to turn full handshaking off for better performance, the line should look something like:

```
DEVICE=\TSCSI\MA348.SYS /M1
```

After making this change and saving CONFIG.SYS back to your boot drive, you must reboot your system for the change to take effect.

4.2 Testing Blind Mode Operation

After modifying your CONFIG.SYS file and rebooting, you should immediately conduct some simple tests to determine whether your installation is compatible with blind mode. We recommend following this sequence:

1. Observe the system bootup closely. As the CD-ROM and/or hard disk drivers load, watch for messages like **No SCSI devices detected**, **No Boot Record Found**, etc. As MSCDEX loads, watch for a **CDR103: CDR0M not High Sierra or ISO-9660 format** error message. If any of these messages appear, your system configuration does not support blind mode.
2. If step 1 reveals a problem, you might be able to operate in blind mode by setting your computer's CPU speed to a lower value. This is generally done with a software setup routine—see your computer's documentation for details.
3. If step 1 reveals a problem and a computer speed decrease doesn't help, then you must remove the /M1 switch from CONFIG.SYS immediately and reboot. Continued operation of an incompatible system will result in SCSI data corruption!
4. If step 1 reveals no problems during bootup, we recommend the following additional tests:
 - Perform a DIR command on all SCSI devices to see if the directory structure is correctly reported. Do not run any other DOS commands yet. If a problem is evident (such as incorrect filenames, garbage

characters appearing in the directory listing, etc.), you probably do not have blind mode compatibility and should remove the /M1 switch from CONFIG.SYS. If no problems are noted, proceed to the next step.

- Perform a CHKDSK command on all hard disk drives (without the /F option!) and/or a CHKCD (supplied with your software) command on all CD-ROM drives. If a problem is evident (such as absurdly wrong numbers being reported), you probably do not have blind mode compatibility and should remove the /M1 switch from CONFIG.SYS. If no problems are noted, proceed to the next step.
 - If no problems are found so far, try copying a large (greater than 100 KB, if possible) file from the SCSI device to a non-SCSI hard disk or floppy drive. After the copy is complete, use the DOS COMP command to compare the new copy to the original file. If a problem is evident (such as the file comparison failing), you probably do not have blind mode compatibility and should remove the /M1 switch from CONFIG.SYS. If no problems are noted, proceed to the next step.
 - If no problems are found, copy a large file from your non-SCSI drive to the SCSI device(s). Again, compare the two files with the COMP command and if a problem is evident (such as the file comparison failing), you probably do not have blind mode compatibility and should remove the /M1 switch from CONFIG.SYS.
5. If, after following these procedures, you've found no problems—congratulations! It's likely that your system is fully compatible with blind mode and your **MiniSCSI Plus** hardware will now operate considerably faster than before (but see *Section 4.3*).

If you change your computer's SCSI device configuration, you should rerun the above test sequence to make sure any newly-added devices are compatible with blind mode. It's possible to add a new device to a compatible system and in doing so eliminate blind-mode compatibility.

We recommend that, if you share your **MiniSCSI Plus** adapter among several systems or carry it for use on other people's systems, you do not run with the /M1 switch enabled unless you are absolutely sure that the other systems are compatible. Changes may take place to the system configuration in your absence! It's better to run a little slower than to take a chance of possibly corrupting data.

4.3 Additional /M switch options

In addition to /M0 and /M1, there are two additional settings: /M2 and /M3. These correspond to /M0 and /M1, but force the adapter to operate in unidirectional mode. A few computers (such as the NEC Prospeed SX/20) are incorrectly seen by the **MiniSCSI Plus** adapter as being equipped with a bidirectional parallel port, instead of the actual unidirectional configuration. This situation can cause data corruption, but using /M2 (instead of /M0) or /M3 (instead of /M1) will force the **MiniSCSI Plus** adapter to use unidirectional mode and should fix the problem.

5.0 SCSI Connector Pinouts

This section documents the SCSI interface connector on the **MiniSCSI Plus** adapter as well as typical connectors found on SCSI devices. Internal SCSI devices commonly use a 50-pin header connector (*SCSI specification Alternative 1*), consisting of two rows of 25 male contacts with adjacent contacts 2.54 mm (0.1 inch) apart, as shown in *Figure 3*.

A typical single-ended shielded SCSI device 50-pin connector (*SCSI specification Alternative 2*) is shown in *Figure 4*; this connector is most often used with an external SCSI device.

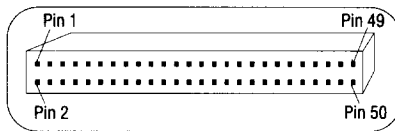

Figure 3 Internal Connector

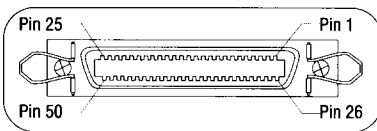

Figure 4 Device Connector

Table 1 lists the pin assignments for each connector type. Definitions of the various signals may be found in any SCSI design reference book. The SCSI interface is fully defined in **ANSI X3.131-1986**; this document is available from Global Engineering Documents, 2805 McGaw Ave, Irvine, CA 92713-9539 USA, telephone (714) 261-1455.

Pin			Pin		
Alt. 1 (Fig. 3)	Alt. 2 (Fig. 4)	Function	Function	Alt. 1 (Fig. 3)	Alt. 2 (Fig. 4)
1	1	Gnd	-DB0	2	26
3	2	Gnd	-DB1	4	27
5	3	Gnd	-DB2	6	28
7	4	Gnd	-DB3	8	29
9	5	Gnd	-DB4	10	30
11	6	Gnd	-DB5	12	31
13	7	Gnd	-DB6	14	32
15	8	Gnd	-DB7	16	33
17	9	Gnd	-DBP	18	34
19	10	Gnd	Gnd	20	35
21	11	Gnd	Gnd	22	36
23	12	Gnd	Gnd	24	37
25	13	Open	Tempwr	26	38
27	14	Gnd	Gnd	28	39
29	15	Gnd	Gnd	30	40
31	16	Gnd	-ATN	32	41
33	17	Gnd	Gnd	34	42
35	18	Gnd	-BSY	36	43
37	19	Gnd	-ACK	38	44
39	20	Gnd	-RST	40	45
41	21	Gnd	-MSG	42	46
43	22	Gnd	-SEL	44	47
45	23	Gnd	-C/D	46	48
47	24	Gnd	-REQ	48	49
49	25	Gnd	-I/O	50	50

Table 1 SCSI Connector Pin Assignments



Made From Recycled Materials

Printed in USA

Copyright

Copyright © 1993 Trantor Systems Limited. All Rights Reserved. No part of this publication may be reproduced, stored in a retrieval system, or transmitted in any form or by any means, electronic, mechanical, photocopying, recording or otherwise, without the prior written consent of Trantor Systems Limited 5415 Randall Place, Fremont, CA 94538.

Trademarks

MiniSCSI and Trantor are trademarks of Trantor Systems Limited which may be registered in some jurisdictions. All other trademarks used are owned by their respective owners.

Changes

The material in this manual is for information only and is subject to change without notice.

Trantor reserves the right to make changes in the product design without reservation and without notification to its users.

Technical Support

Trantor host adapters have been specifically developed for easy installation and use. We hope that our manuals and the on-screen instructions and help are complete and clear enough to meet your needs. If you need further help, please contact us.

The Trantor Electronic Bulletin Board Service (EBS) provides information on software upgrades, new releases, technical advice, and other topics. You can reach the EBS 24 hours a day at 510-656-5159; 9600 v.32 bis, 8 data bits, 1 stop bit, and no parity.

To contact the Technical Support Hot Line, call 800-959-SCSI (7274) or 408-945-2550, M-T: 6:00 a.m. to 5:00 p.m., F: 6:00 a.m. to 3:00 p.m., Pacific time.

Warranty, Service, Support

If you have technical questions not answered by this guide, contact your dealer first. If your dealer is unable to answer your questions, you may contact Trantor directly.

Trantor Products Limited Warranty

Trantor Systems Limited (hereafter Trantor) warrants this hardware product to be free from defects in material and workmanship under the following terms.

Warranty Term

Labor is warranted for (1) One Year from the date of the first consumer purchase. Parts are warranted for (1) One Year from the date of the first consumer purchase. Magnetic media on which the software is supplied is warranted for (90) Ninety Days from the date of the first consumer purchase. Note that only the media itself is warranted, not the software; please refer to the License Agreement on the software package.

Who Is Protected

This warranty may be enforced only by the first consumer purchaser.

What Is Covered and What Is Not Covered

Except as specified below, this warranty covers all defects in material or workmanship in this product. The following are not covered by the warranty.

1. Any product which is not distributed by Trantor or an Authorized Distributor or which is not purchased from an authorized Trantor dealer. If you are uncertain as to whether a dealer is authorized please contact Trantor.
2. Any product on which the serial number (if applicable) has been defaced, modified or removed.
3. Damage, deterioration or malfunction resulting from:
 - a. Accident, misuse, abuse, neglect, fire, water, lightning or other acts of nature, commercial or industrial use, unauthorized product modification, or failure to follow instructions supplied with the product.
 - b. Repair or attempted repair by anyone not authorized by Trantor.
 - c. Any shipment of the product (claims must be presented to the carrier).
 - d. Removal or installation of the product.
 - e. Any other cause which does not relate to a product defect.
4. Cartons, carrying cases, batteries, external cabinets, or any accessories used in conjunction with the product.

What We Will Pay For And What We Will Not Pay For

We will pay all labor and material expenses for covered items, but we will not pay for the following:

1. Removal or installation.
2. Costs of initial technical adjustments (set-up), including adjustment of user controls and software installation and configuration. These costs are the responsibility of the Trantor dealer from whom the product was purchased.
3. Shipping charges to or from Trantor.

Disclaimer Of Implied Warranties

EXCEPT FOR THE EXPRESS WARRANTIES SET FORTH ABOVE, TRANTOR GRANTS NO OTHER WARRANTIES, EITHER EXPRESS OR IMPLIED, ON EQUIPMENT INCLUDING ALL IMPLIED WARRANTIES OF MERCHANTABILITY OR FITNESS FOR A PARTICULAR PURPOSE.

Exclusion Of Damages

TRANTOR'S LIABILITY FOR ANY DEFECTIVE PRODUCT IS LIMITED TO THE REPAIR OR REPLACEMENT OF THE PRODUCT AT OUR OPTION. TRANTOR SHALL NOT BE LIABLE FOR:

1. DAMAGE TO OTHER PROPERTY CAUSED BY ANY DEFECTS IN THIS PRODUCT, DAMAGES BASED UPON INCONVENIENCE, LOSS OF USE OF THE PRODUCT, LOSS OF TIME, COMMERCIAL LOSS, OR
 2. ANY OTHER DAMAGES, WHETHER INCIDENTAL, CONSEQUENTIAL OR OTHERWISE.
- SOME STATES DO NOT ALLOW EXCLUSION OF AN IMPLIED WARRANTY AND/OR DO NOT ALLOW THE EXCLUSION OR LIMITATION OF INCIDENTAL OR CONSEQUENTIAL DAMAGES, SO THE ABOVE LIMITATIONS AND EXCLUSIONS MAY NOT APPLY TO YOU.

How State Law Relates To The Warranty

This warranty gives you specific legal rights, and you may also have other rights which vary from state to state.

Trantor Software License And Warranty

Please refer to the separate Trantor Software License and Warranty which came with your Trantor distribution diskette.

FCC Compliance Statement

Your Trantor SCSI host adapter is covered by FCC rules for a Class B computing device.

The following information is provided for the information and guidance of the user. Use shielded cables to attach only peripherals (computer input/output devices, terminals, printers etc.) certified to comply with the Class B limits to your computer.

This device complies with part 15 of the FCC rules. Operation is subject to the following two conditions: (1) This device may not cause harmful interference, and (2) this device must accept any interference received, including interference that may cause undesired operation. FCC regulations, Part 15 prescribed by the Federal Communications Commission (FCC) specify that we provide the following information:

This equipment generates and uses radio frequency energy and, if not installed and used properly, in strict accordance with the manufacturer's instructions, may cause interference to radio and television reception. It has been type tested and found to comply with the limits for a Class B computing device in accordance with the specification in Subpart J of Part 15 of FCC Rules, which are designed to provide a reasonable protection against such interference in a residential installation. However, there is no guarantee that interference will not occur in a particular installation.

If this equipment does cause interference to radio or television reception, (which you can determine by turning the equipment OFF and ON), the user is encouraged to try to correct the interference by one or more of the following measures:

- Reorient the receiving antenna.
- Relocate the computer with respect to the receiver.
- Move the computer away from the receiver.
- Plug the computer into a different outlet so that the computer and receiver are on different branch circuits.

If necessary, consult the dealer or an experienced radio/television technician for additional suggestions. You may find the booklet **How to Identify and Resolve Radio-TV Interference Problems** helpful. This booklet has been prepared by the FCC and is available from the U.S. Government Printing Office, Washington, D.C. 20402; Stock # 004-000-00345-4.